

THIS DRAWING IS UNPUBLISHED. RELEASED FOR PUBLICATION  
 © COPYRIGHT BY TYCO ELECTRONICS CORPORATION. ALL RIGHTS RESERVED.

| LOC | DIST | REVISIONS   |                             |         |        |
|-----|------|-------------|-----------------------------|---------|--------|
| P   | LTR  | DESCRIPTION | DATE                        | DWN     | APVD   |
| AD  | 25   | G           | REVISED PER EC 0512-0552-04 | 29SEP05 | JDP DD |

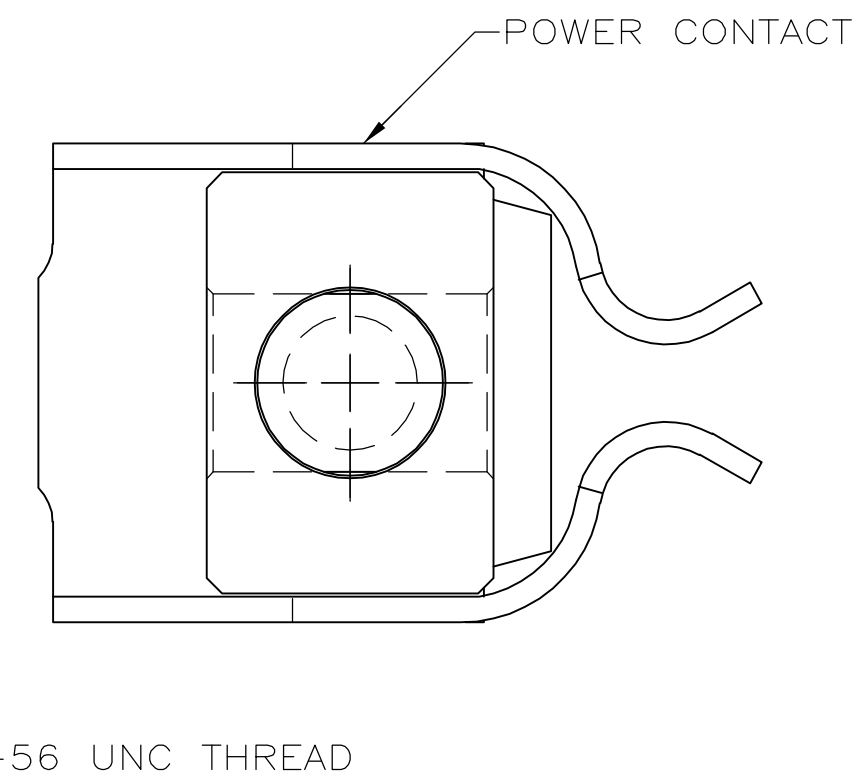
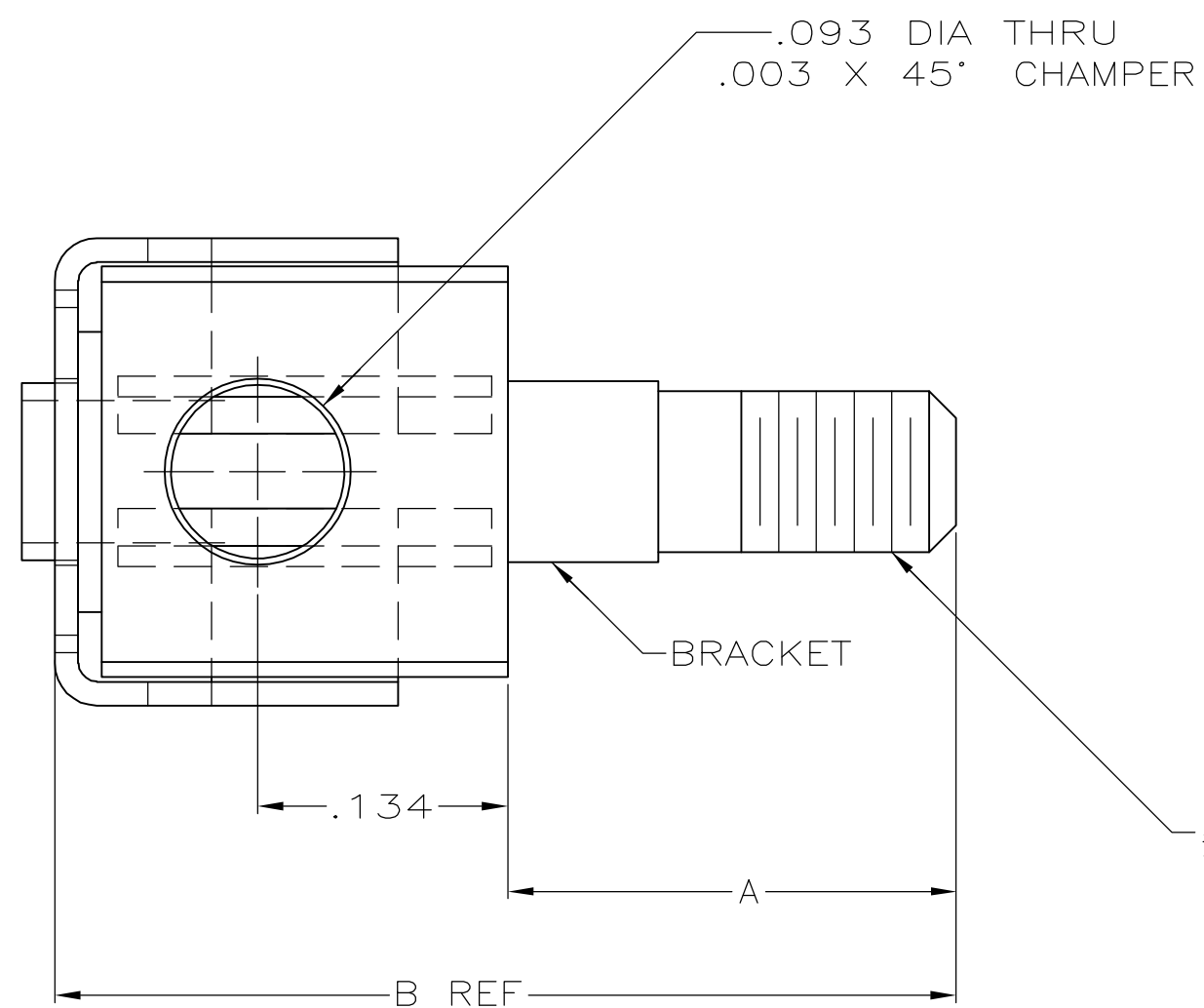
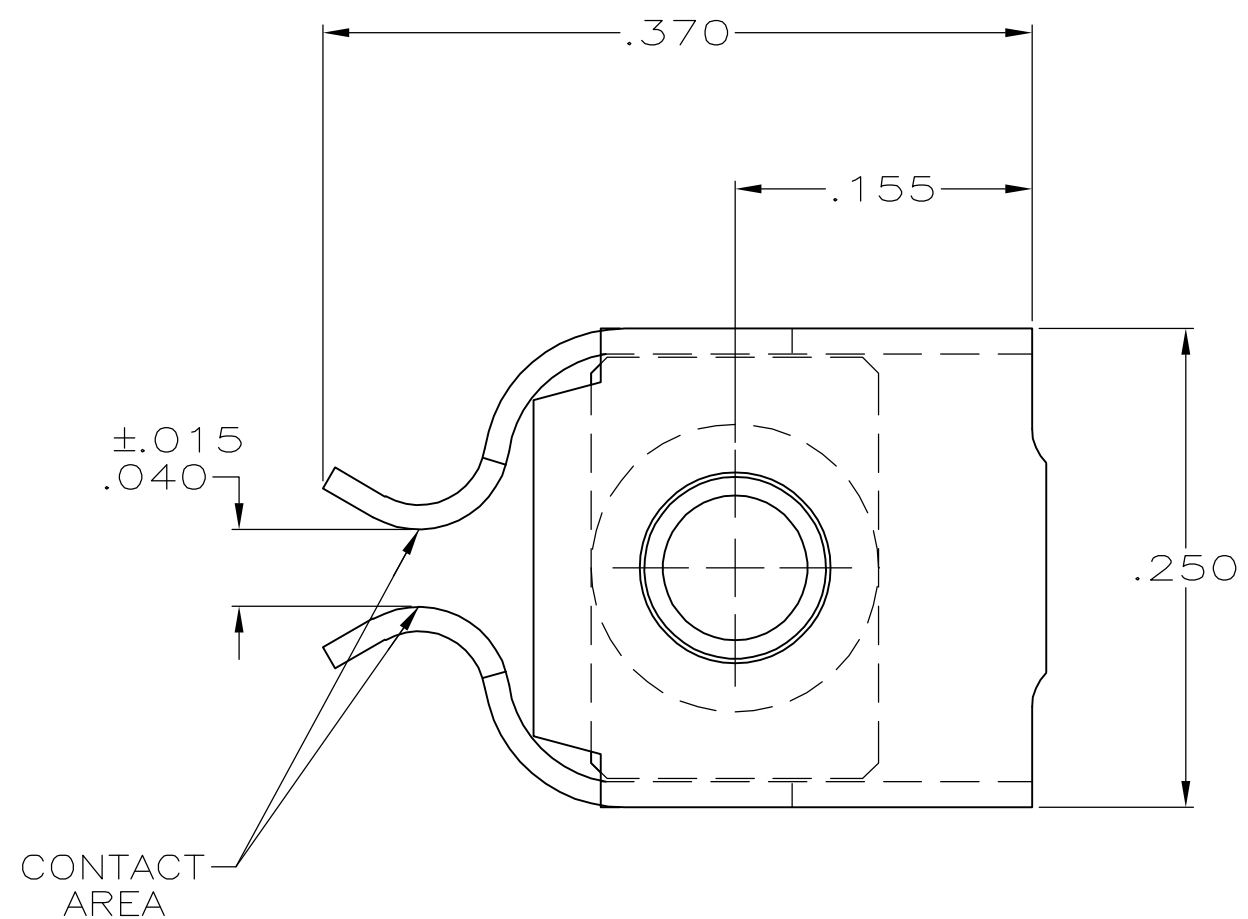

|          |      |      |        |          |
|----------|------|------|--------|----------|
|          | .438 | .185 | △3     | 533065-7 |
|          | .478 | .225 | △3     | 533065-6 |
| OBSOLETE | .565 | .312 | △3     | 533065-5 |
|          | .543 | .290 | △3     | 533065-4 |
|          | -    | -    | -      | -        |
| OBSOLETE | .678 | .425 | △4     | 533065-2 |
| OBSOLETE | .678 | .425 | △3     | 533065-1 |
|          | B    | A    | FINISH | PART NO  |

- △1 CONTACT MATERIAL: PHOSPHOR BRONZE.
- △2 BRACKET MATERIAL: BRASS.
- △3 FINISH: .000050 -.000100 NICKEL UNDERPLATE ALL OVER, .000030 GOLD IN CONTACT AREA, GOLD FLASH ON REMAINDER.
- △4 FINISH: .000050 -.000100 NICKEL UNDERPLATE ALL OVER, .000050 GOLD IN CONTACT AREA, GOLD FLASH ON REMAINDER.

THIS DRAWING IS A CONTROLLED DOCUMENT.

|                  |                   |          |        |   |               |
|------------------|-------------------|----------|--------|---|---------------|
| DWN              | DAVID LEE HOFFMAN | 12/11/89 |        | Tyco Electronics Corporation  |               |
| CHK              | G. SKIPPER        | 1-31-94  |        | Harrisburg, PA 17105-3608   |               |
| APVD             | -                 | -        | NAME   | AMP-HDI SERIES 100 GUIDE PIN POWER CONTACT ASSEMBLY, FOR CENTER GUIDE |               |
| PRODUCT SPEC     | -                 | -        | SIZE   | CAGE CODE   | DRAWING NO    |
| APPLICATION SPEC | -                 | -        | A2     | 00779   | C=533065      |
| MATERIAL         | △1 △2             | △3       | WEIGHT | -   | RESTRICTED TO |
| CUSTOMER DRAWING |                   |          | SCALE  | 10:1  | SHEET 1 of 1  |
|                  |                   |          | REV    | G   |               |